



# De-icing & Snow-melting Systems by SST Group for a Safe Urban Environment

July 2018

# 1.

## 1. About SST Group

2. Urban space safety challenges and solutions
3. De-icing & snow-melting systems for roofs and gutters
4. De-icing & snow-melting systems for outdoor areas, ramps, and stairs
5. Corrugated stainless steel tubes IWS
6. Water leakage monitoring system Neptun
7. Our advantages



**Europe's largest manufacturer** of electric heating cable systems



**Top-3** global heating cable brands

**40%** of the Russian market of engineering services in architectural and industrial electric heating



**Own production** of electroconductive plastics and self-regulating heating cables

SST Group products and solutions are **exported to 47 countries**



Over **25 years** of success on the market

**10 000**  
projects completed

**45 000 m<sup>2</sup>**  
of production facilities

**13 200 000**  
electric heating systems  
manufactured





## Our Mission

Our mission is to facilitate safety and security of infrastructure facilities and industrial companies' production and technological processes by providing the best-in-class electric heating cable and heat tracing solutions.



## Our Values



Innovation



Quality



Responsibility



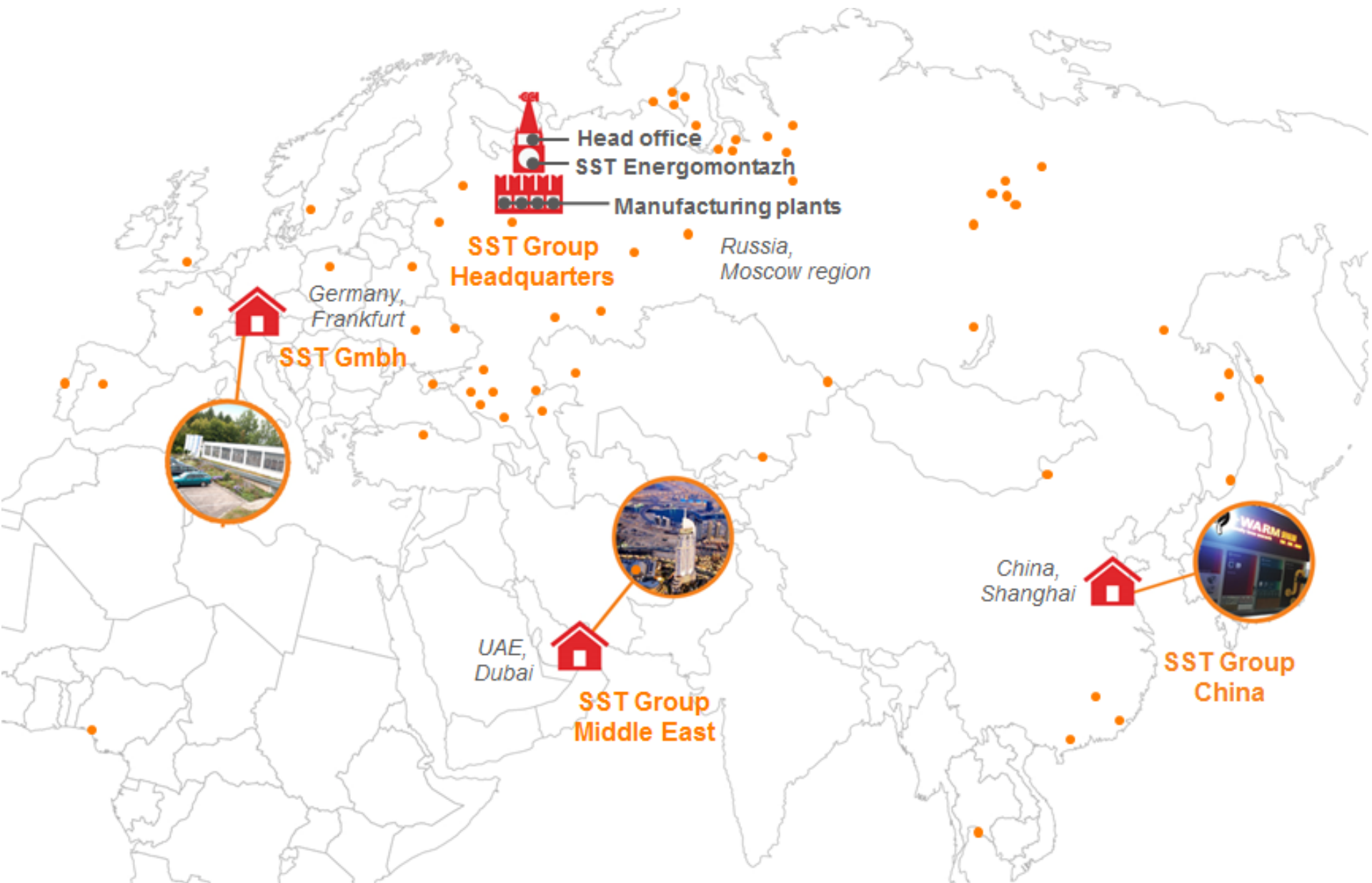

Management



## SST Invest

Financial management & warranties

Engineering



## SST Energomontazh

R&D, design engineering, logistics & supply, installation & supervision, start-up & commissioning, after-sales service

Sales & Sales Support



## SST GmbH



## SST Group Middle East



## SST Group China

Manufacturing

## OKB Gamma

Manufacturing of all components of heat tracing systems



Series-Resistance Heating Cables



Self-Regulating Heating Cables



Ex-proof junction boxes, cable glands



Corrugated stainless steel tubes & fittings

## SST Energomontazh



Electrical cabinets & automation systems

SST Group Revenue, Million Euros

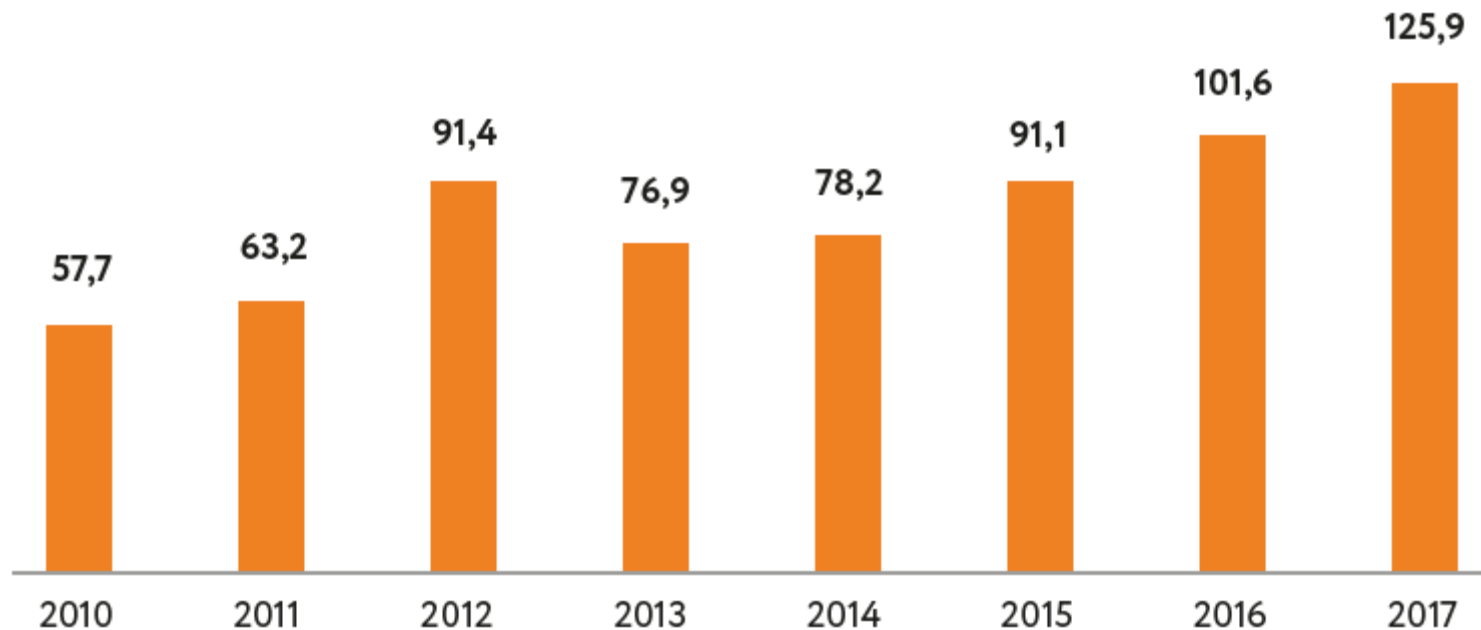

- Stable revenue growth over the past 7 years, despite economic crisis in Russia
- CAGR 2010-2017 = 12%



D-U-N-S® registered company  
with number 566541026



## Manufacturing of all components of electric heating cable systems:

- ✓ self-regulating heating cables
- ✓ series-resistance heating, MI cables
- ✓ power & control cables
- ✓ junction boxes
- ✓ corrugated tubes
- ✓ switchboard cabinets

**60 000 km / year**

## cable manufacturing capacity

**11** extrusion lines      **10** twister machines  
**16** braiding machines    **6** drawing machines

...and other specialized cutting-edge equipment:  
electron-beam machining (EBM), polymer compounders,  
testing equipment etc.





**State Historical  
Museum**



**GUM Department  
Store**



**Bolshoi Theater**



**Cathedral of Christ  
the Savior**

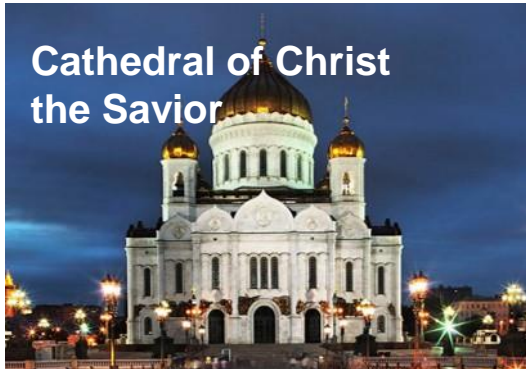

**Government House**



**Central Bank**



**Manezhnaya Square**



**Moscow City**

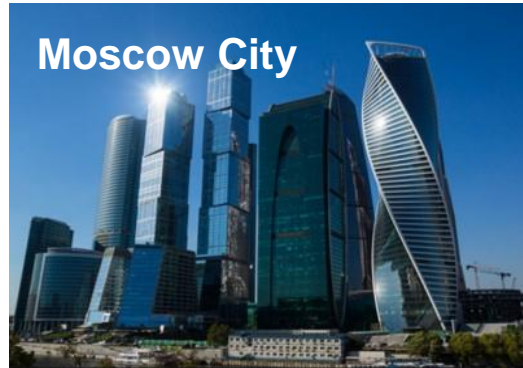

**Kazan Kremlin**



# 2.

1. About SST Group
- 2. Urban space safety challenges and solutions**
3. De-icing & snow-melting systems for roofs and gutters
4. De-icing & snow-melting systems for outdoor areas, ramps, and stairs
5. Corrugated stainless steel tubes IWS
6. Water leakage monitoring system Neptun
7. Our advantages

## Negative effects of ice on roofs, ramps and stairs:

- Falling icicles is a source of hazard to human life, motor vehicles, building facades
- Increased mechanical load on roofs and gutters reduces their service life
- Blocked gutters and water accumulation causes leakages.
- The need for mechanical cleaning reduces the service life of the roofing.
- Ice on stairways and ramps leads to an increased risk of injury to pedestrians.
- In the absence of a heating system, property maintenance requires dedicated full-time staff members.
- Ice causes significant damage to the road surface during mechanical snow and ice removal, thus shortening the service life of the road paving.





## De-icing & snow-melting systems based on series-resistance and self-regulating heating cables:

- heating of roofs and gutters
- heating of outdoor areas, ramps, and stairs
- heating of concrete
- solutions for heating outdoor sports grounds
- heating systems for indoor sports facilities
- heating solutions for alpine ski and bobsleigh trails
- soil heating under freezer units
- snow cover height measurement systems



## Other solutions for a safe urban environment

- flexible corrugated stainless steel pipes IWS for heating, water supply, fire-fighting and gas supply systems
- water leakage monitoring systems Neptun





SST Group is the only manufacturer of conductive plastics and self-regulating cables in Russia and one of the few worldwide.

**Operating principle of self-regulating heating cables:**

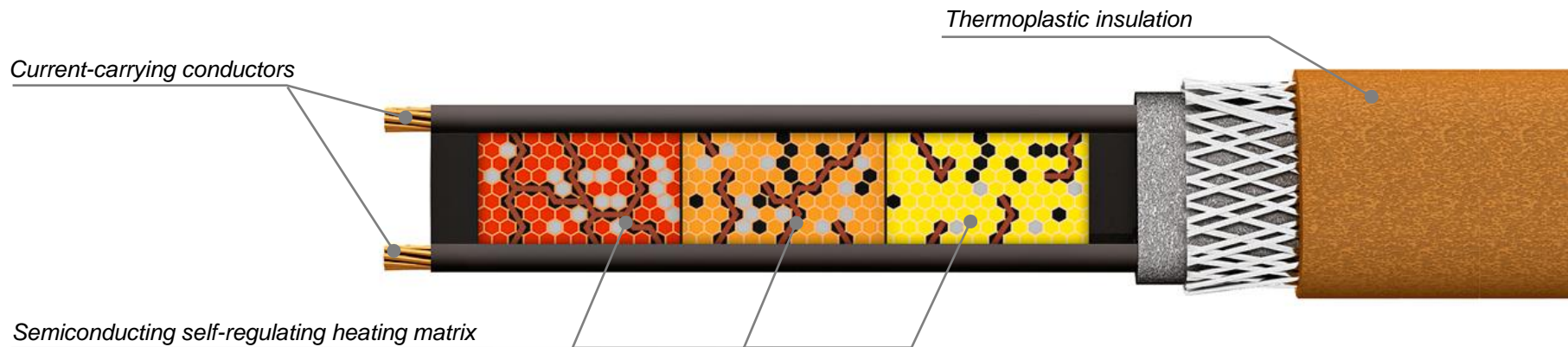

Self-regulating cable has two copper conductors embedded in an extruded semiconductor material (matrix). For electrical safety and protection, the matrix is insulated with thermoplastic with a tinned copper braiding on top of it.

A unique property of the cable is that the heating power varies with the ambient temperature. In other words, when it's cold outside, the heating power adjusts upward, when it gets warmer, it adjusts downward or switches off.

**Energy consumption is kept at an optimum level, the system is automatically regulated and there is no need to monitor the system on a daily basis.**



## Efficiency

- ✓ Extended service life of infrastructure
- ✓ Reduced cost of repairs and maintenance
- ✓ Low energy consumption



## Safety

- ✓ Eliminated risk of injuries and fatal accidents due to slipping on ice / icicles falling
- ✓ Protection against property damage



## Ease of use

- ✓ Simply attach the heating cable and connect to a power source
- ✓ The system operates in an automatic mode



## Durability

- ✓ The heating cable has a service life (depending on the cable type) of at least 25 years.

# 3.

1. About SST Group
2. Urban space safety challenges and solutions
- 3. De-icing & snow-melting systems for roofs and gutters**
4. De-icing & snow-melting systems for outdoor areas, ramps, and stairs
5. Corrugated stainless steel tubes IWS
6. Water leakage monitoring system Neptun
7. Our advantages



## De-icing Systems for Roofs and Gutters

**Electric heating cable system for roofs and gutters** is designed to prevent the ice from blocking water drains and to ensure the removal of melt water in the winter.





- Protect people, motor vehicles and property from falling ice
- Extend the service life of the roof and gutters
- Reduce the roof maintenance costs
- Prevent damage to the building facades



- 1 - downspouts
- 2 - gutters
- 3 - spouting
- 4 - roof drains
- 5 - guide chutes
- 6 - neck gutters
- 7 - water outlet
- 8 - cornice
- 9 - water drip
- 10 - flat roofing
- 11 - gutter catchment area
- 12 - input heating area
- 13 - roof edge
- 14 - snow retention
- 15 - ground drainage chute
- 16 - drainage well

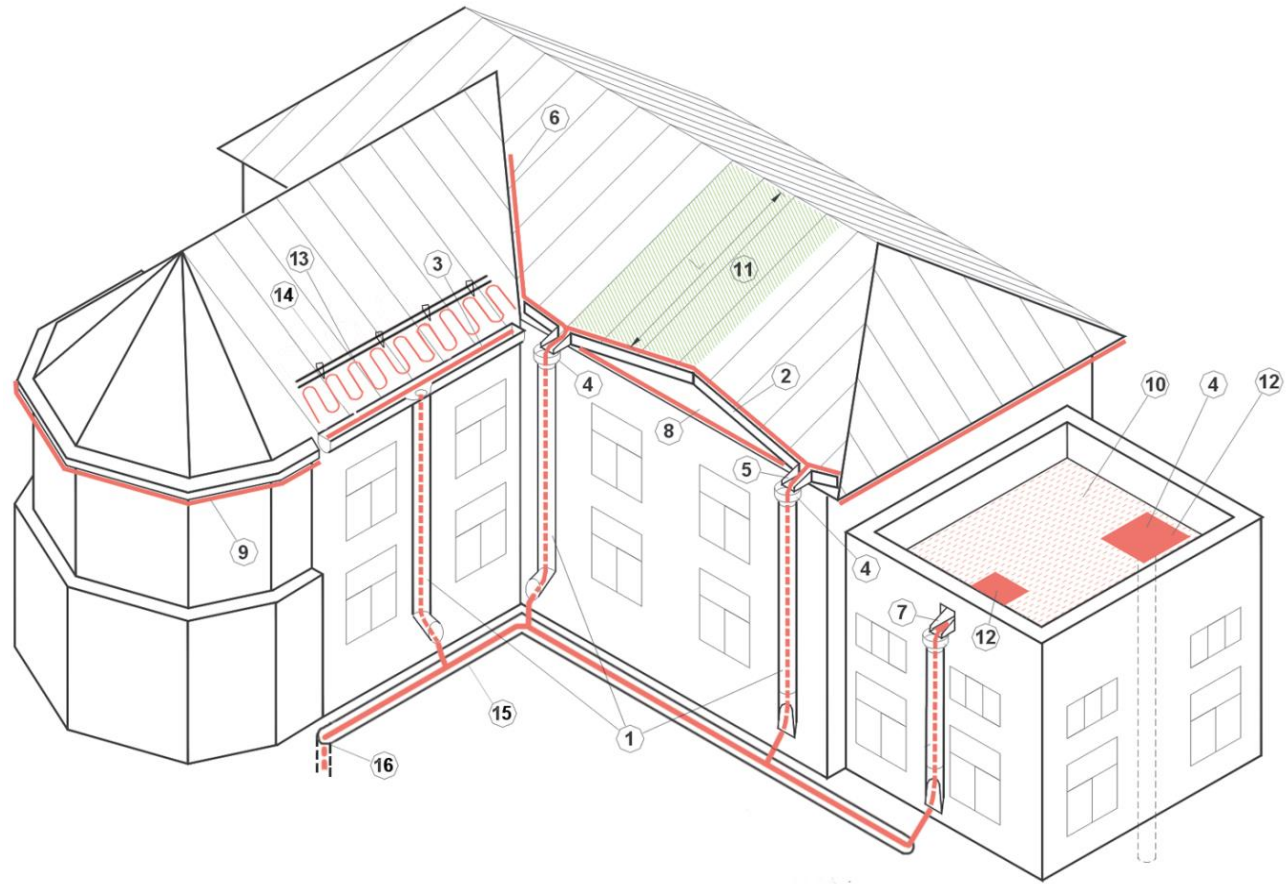





**Shopping Centers**

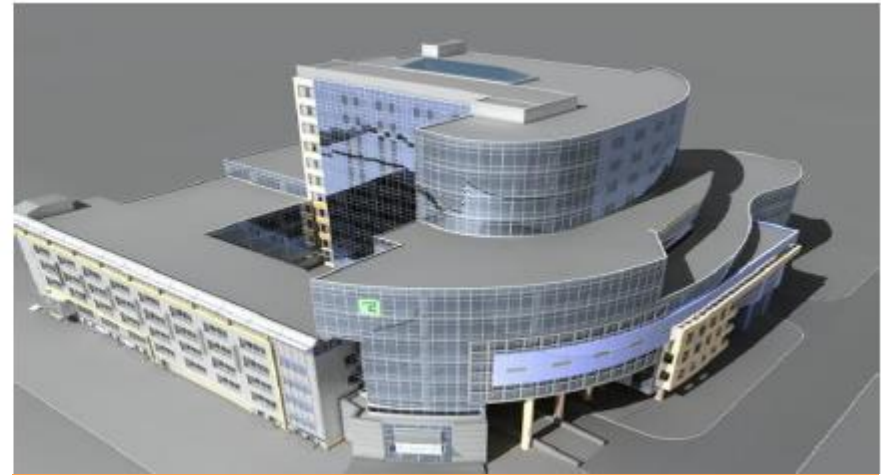

**Office Buildings & Hotels**



**Glazing Roofs**



**Residential Complexes**



**Schools & Kindergartens**



**Stadiums & Swimming Pools**



**Banks**



**Hospitals**



## Heating cables

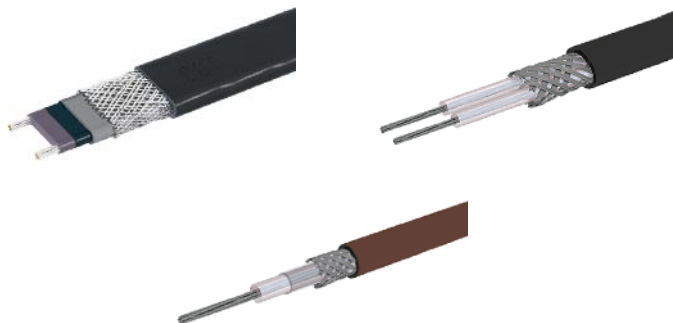

## Accessories and fasteners

Assembly kits for making heating cable sections

Fasteners

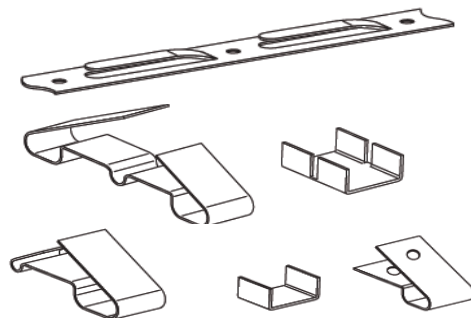

## Thermostats and sensors



TP-140



PT-330



PT-610



PTM-2000

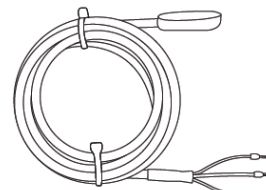

Temperature sensor

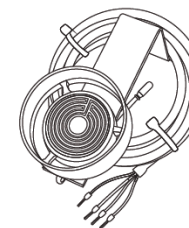

Precipitation sensor

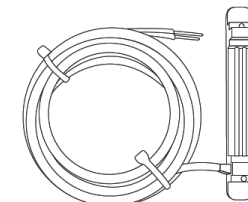

Water sensor

Heated structure	Application	Operating ambient temperature range	Specific nominal heating power, W/m	Heating cable	Thermostats
Cornice water drips	Preventing dangerous icicle formation on the drips	From + 5 °C to -15 °C* * as requested by the customer	90...100	FreezStop KCTM	TP-140, TP-190, TP-610 PT-330, PTM-2000
Roof edges	Preventing ice and snow accumulation on the edge of the roof		250...300	MHT HCKT FreezStop KCTM	
Gutters, neck gutters, and downspouts	Preventing blockage of water drains with snow and ice to ensure melt water removal		25...130	MHT HCKT TMΦ FreezStop KCTM	
Roof drains	Preventing blockage of water drains with snow and ice to ensure melt water removal		250...300	FreezStop KCTM	

# 4.

1. About SST Group
2. Urban space safety challenges and solutions
3. De-icing & snow-melting systems for roofs and gutters
- 4. De-icing & snow-melting systems for outdoor areas, ramps, and stairs**
5. Corrugated stainless steel tubes IWS
6. Water leakage monitoring system Neptune
7. Our advantages





**Electric heating systems for open outdoor areas** are used to prevent ice formation and to remove snow from outdoor areas, pedestrian crossings, roads, ramps, sidewalks, stairs, garage driveways, entrance units.

Since 2013, electric heating systems by SST Group have been used in the reconstruction of pedestrian crossings in Moscow and the Moscow Region.

Their combined length is more than **400 km**.



## Heating of outdoor areas, stairs, and ramps

prevents ice formation in areas with pedestrian and motor vehicle traffic in winter



## Heating of helipads

keeps takeoff and landing and maintenance areas free of snow



## Heating of floors in process areas

ensures flushing into the drainage with water-based agents in winter



## Heating of soccer fields and sports grounds

prolongs the playing season



### Soil heating systems for greenhouses, interior gardens, glasshouses, flowerbeds, and seedling beds

Accelerates plant growth and reproduction.

Greenhouses with soil heating systems can be operated from early spring to late fall to achieve an early harvest of the agricultural produce and to extend the growing season.



### Soil heating systems for refrigerator and freezer units

Creates a thermal barrier that prevents soil freezing and heaving immediately under the freezer unit floor and prevents damage to the refrigerator unit floor and load-bearing foundations, including support pillars.





## Heating cables



## Fasteners

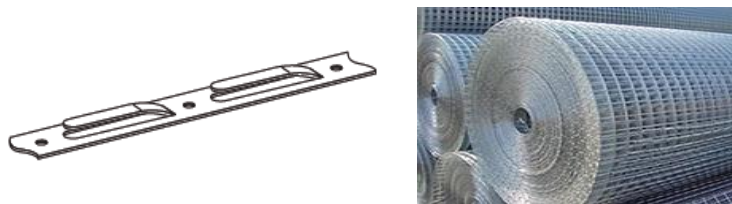

## Thermostats and sensors



TP-140



PT-330



PT-610



PTM-2000



Temperature sensor



Precipitation sensor



Water sensor



# 5.

1. About SST Group
2. Urban space safety challenges and solutions
3. De-Icing & snow-melting systems for roofs and gutters
4. De-Icing & snow-melting systems for outdoor areas, ramps, and stairs
- 5. Corrugated stainless steel tubes IWS**
6. Water leakage monitoring system Neptun
7. Our advantages

OKB Gamma (part of SST Group) is the only Russian manufacturer of flexible corrugated stainless steel tubes.

**2013**

Mass production  
launched

**3,000 km**

Annual production capacity of  
OKB Gamma

**17**

Corrugated tube sizes  
and 20 smooth-wall tube types





Hydronic underfloor heating



Heating and heat supply stations



Cable conduits



Water supply

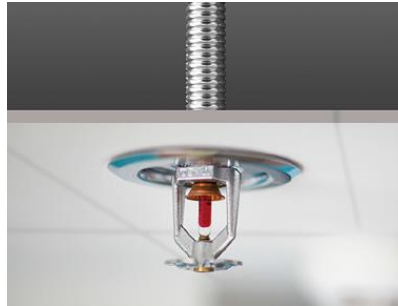

Firefighting



Gas supply

## Advantages of IWS Tubing

---



- A **universal solution** for utility systems
- Easy to cut and bend for **easy installation**
- Bending **does not alter** the **cross section** — no microcracking and no mechanical stress of the metal
- Annealed pipe has **improved plasticity** and **flexibility** and a significant safety margin for multiple bending
- Resistant to **aggressive environments**
- **Withstands linear extensions and shrinkage** when exposed to cyclic temperature effects
- **High reliability** — the pipe is airtight, resistant to high and low temperatures, fire, sparks, rodents, fungus, mold. High resistance to soil subsidence and earthquakes
- **Environmentally friendly** compared to other materials used in the manufacture of cable conduits and wiring. Does not release harmful substances into the environment.



# 6.

1. About SST Group
2. Urban space safety challenges and solutions
3. De-icing & snow-melting systems for roofs and gutters
4. De-icing & snow-melting systems for outdoor areas, ramps, and stairs
5. Corrugated tubes IWS
- 6. Water leakage monitoring system Neptun**
7. Our advantages

**Leakage protection systems Neptun** ensure timely detection and localization of water leaks.

- Leakage protection systems Neptun are composed of electrically driven ball valves, control module, and water leakage sensors.
- In the event of leakage, the sensors instantly and automatically detect the leak, send an alarm to the control module, and the ball valves immediately shut off the supply of cold and hot water. When a water leak is detected, audible or visual alarm is activated.
- Smart home technologies: **Neptun ProW+** with a backup power source supports wired and radio sensors and sends reports to the smartphone app.



# 7.

1. About SST Group
2. Urban space safety challenges and solutions
3. De-icing & snow-melting systems for roofs and gutters
4. De-icing & snow-melting systems for outdoor areas, ramps, and stairs
5. Corrugated tubes IWS
6. Water leakage monitoring system Neptun

## **7. Our advantages**

- ✓ Own production
- ✓ The most advanced materials & equipment
- ✓ Own testing facilities
- ✓ Strict quality control procedures – 100% of our products pass testing
- ✓ All products meet international standards and technical requirements (ATEX, IEC, VDE etc.)
- ✓ Reliable products & systems – operating in the most extreme conditions
- ✓ Solutions for challenging areas: extremely high and low temperature, ex-proof zones
- ✓ Turn-key projects with a single point of responsibility
- ✓ Full engineering support, 100+ design engineers
- ✓ International sales & project support team
- ✓ Warranty and after sales services





1. Design of the best-matched and most cost-effective electric heating system considering the facility's needs
2. Thermal calculations
3. Unified engineering solutions catalogues
4. Simultaneous design of the heating system and auxiliary power network to reduce overall construction costs
5. Engineering economic analysis of the electric heating system

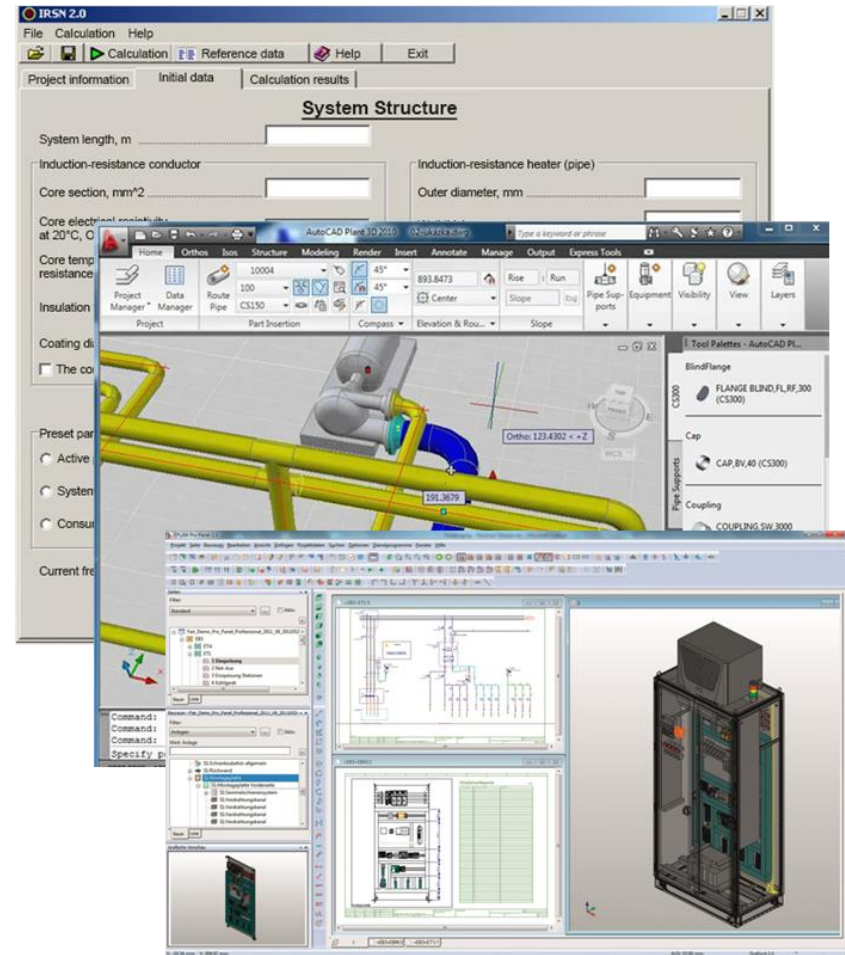

- ✓ All components of the quality management system are in place
- ✓ Compliance with international standards and technical requirements
- ✓ Quality testing procedures at every stage of the project implementation process

## Quality management procedures:

- ✓ Development, coordination, approval and amendment and cancellation of the company standards, controlling & methodology documents, regulations, job descriptions, technical documentation
- ✓ Assignment and duties of quality management representatives and process owners
- ✓ Development, maintenance and usage of sum of process passports

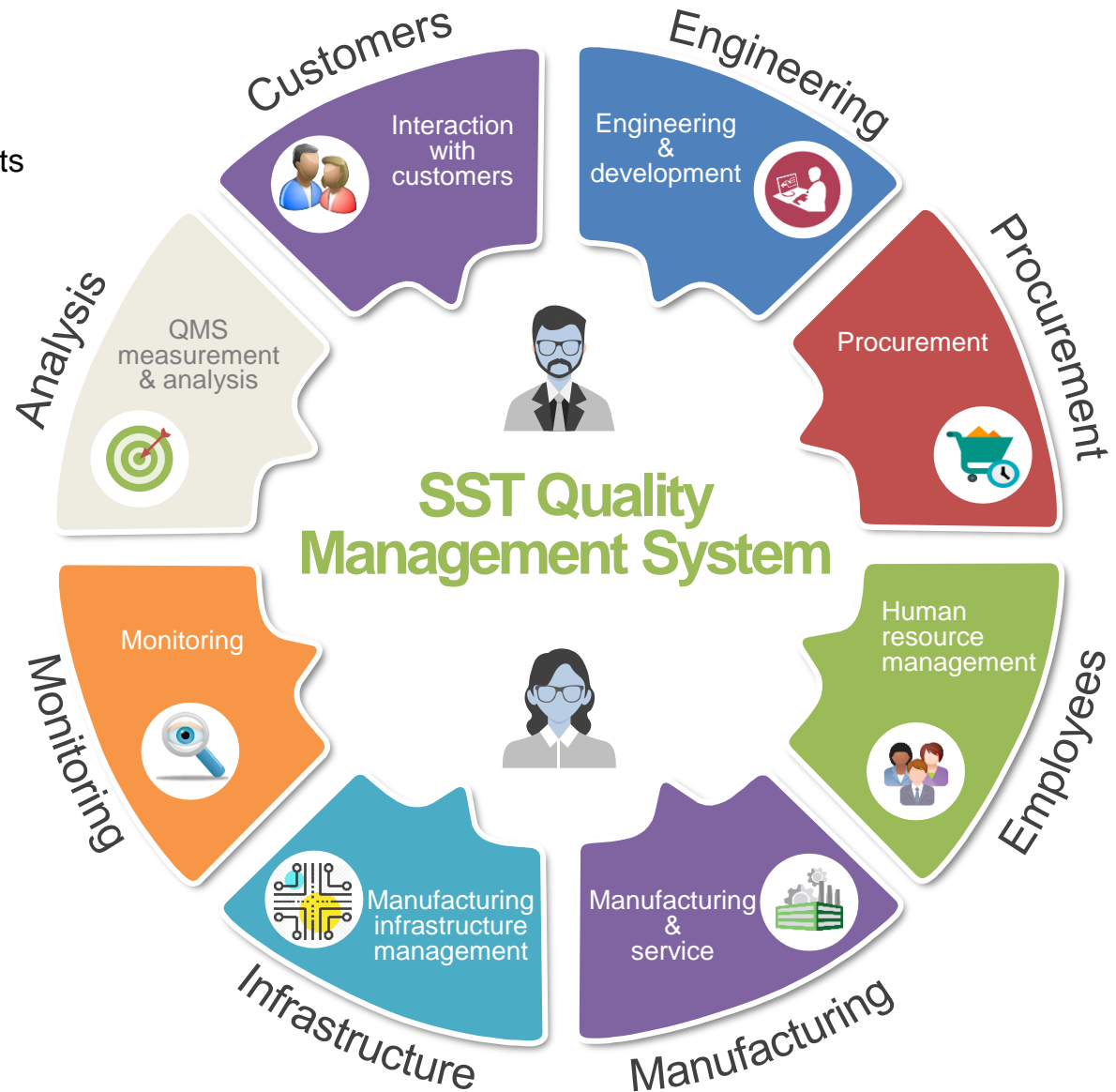

- All products meet international standards and technical requirements
- ISO 9001 Compliance Certification since 2004
- Customs Union Technical Regulations Certificate (TR CU Certificate)
- IEC Ex certificates
- ATEX certificates
- VDE certificates
- Marine certificates





---

# World-Class Electric Heating Solutions

---

[www.sst-international.com](http://www.sst-international.com)